

**ELEVATIONS**

Elevation 1 - Outside View (Scale 1:10)

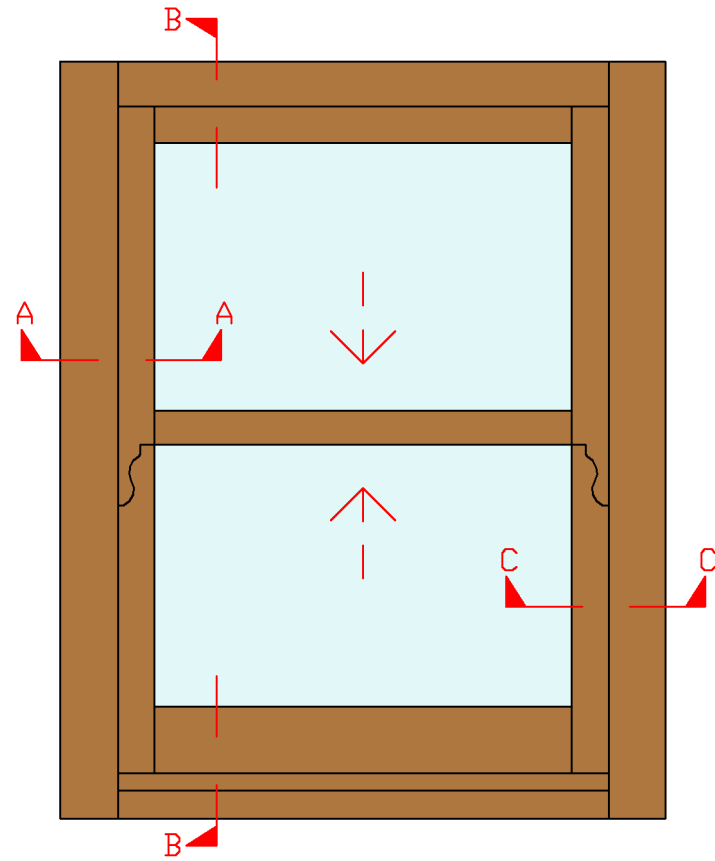

Elevation 2 - Inside View (Scale 1:10)

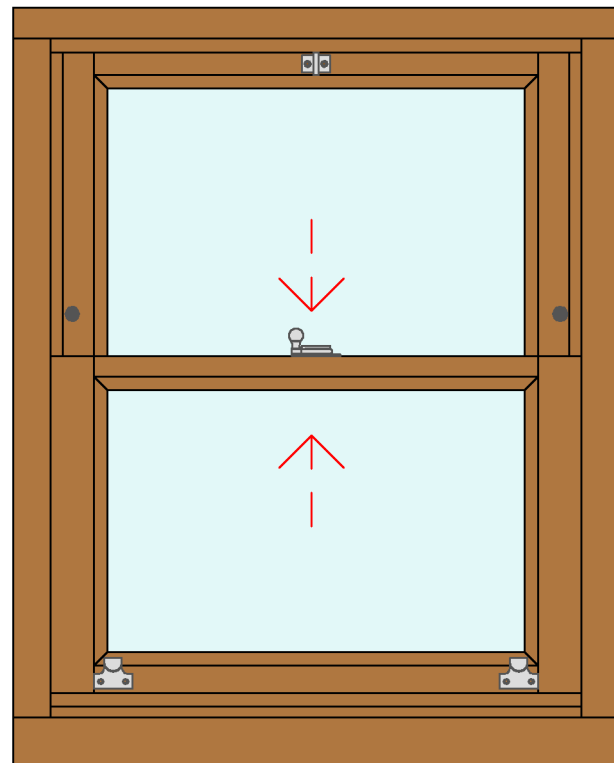

**SECTIONS**

Section A-A - Upper Jamb (Scale 1:2)

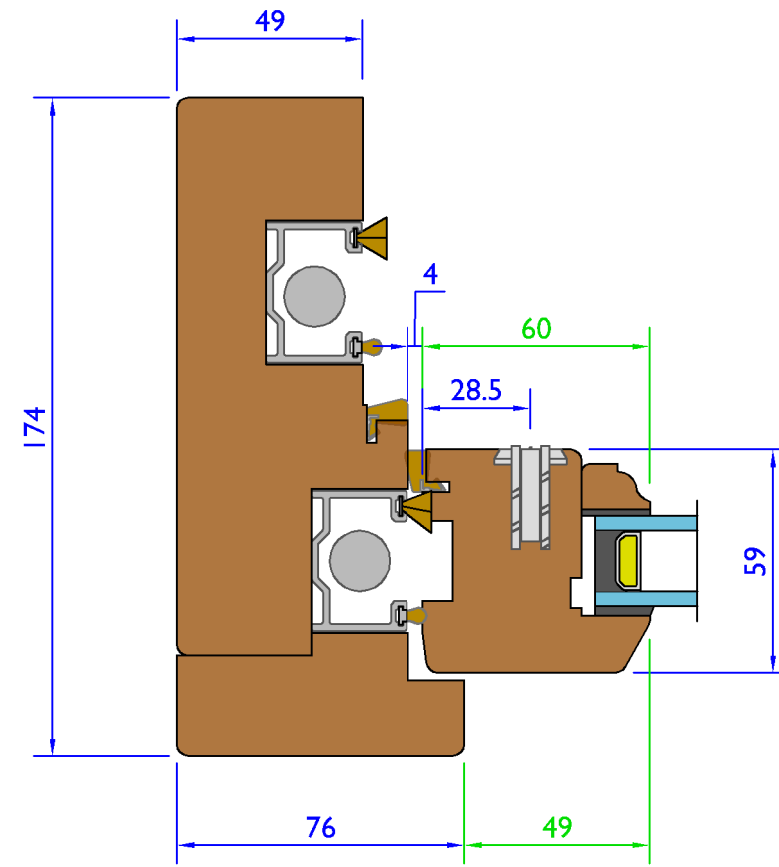

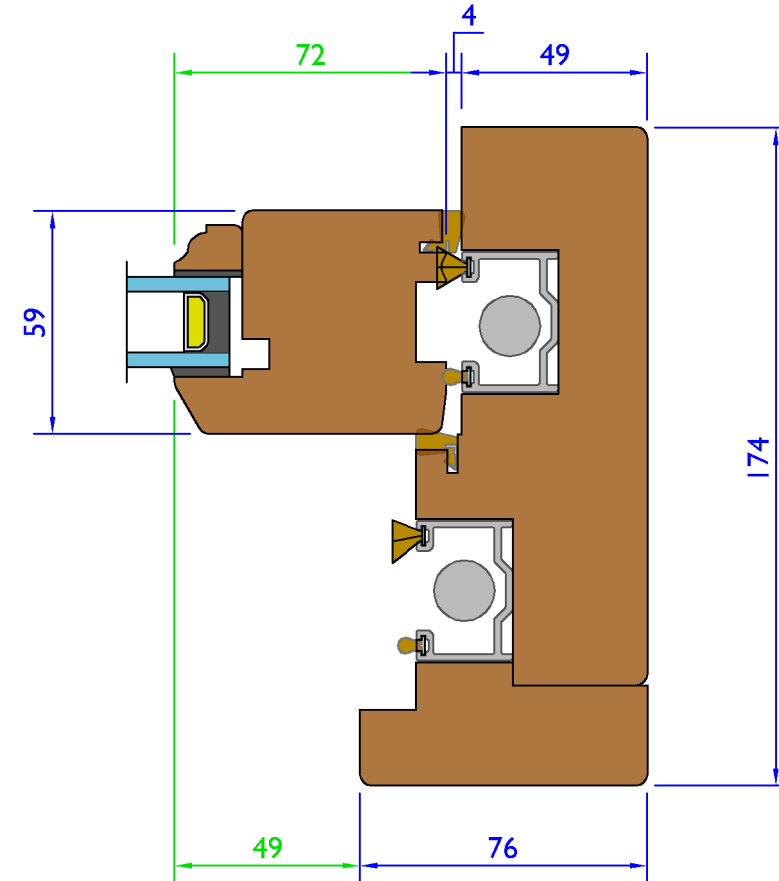

Section C-C - Lower Jamb (Scale 1:2)

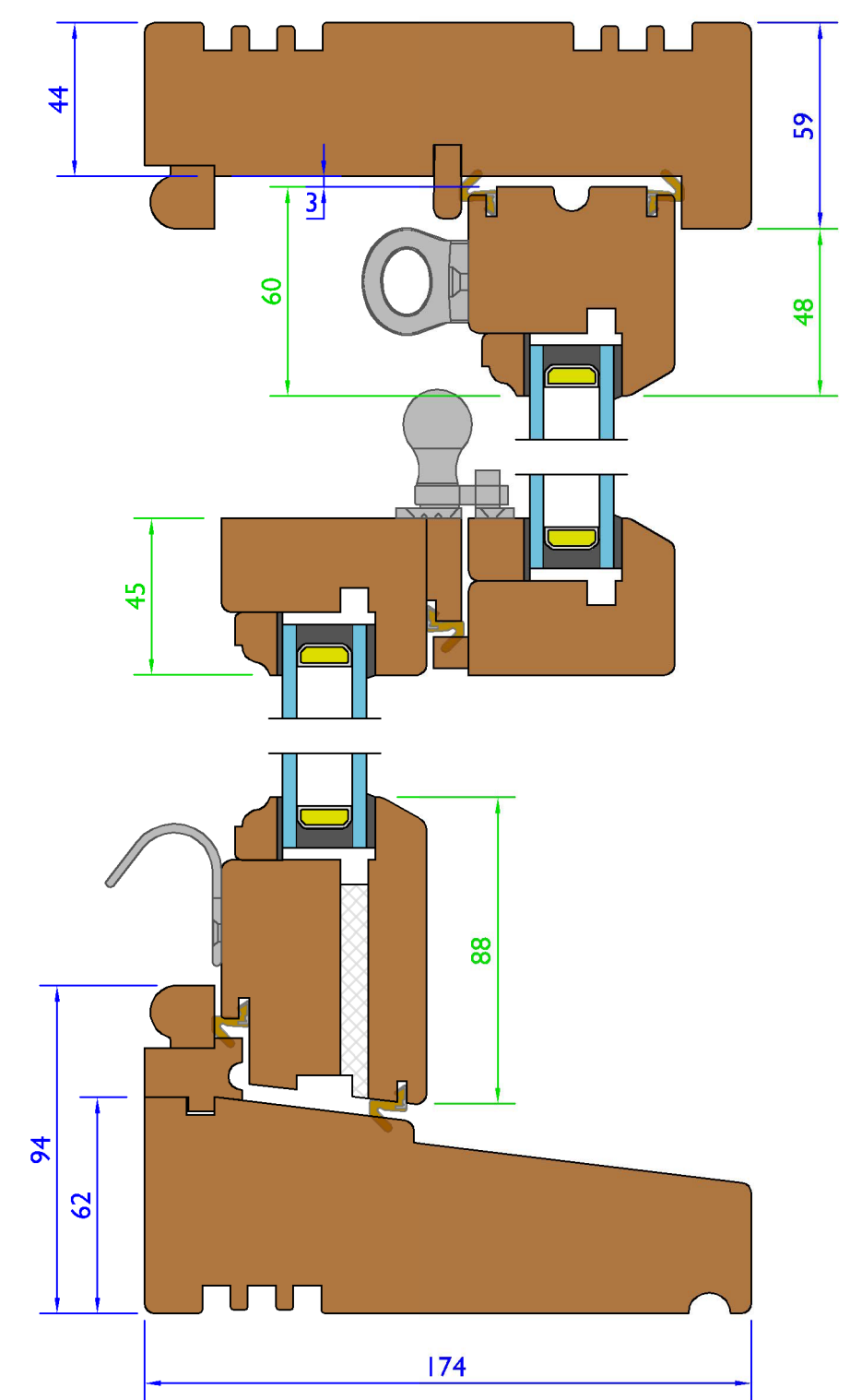

Section B-B - Head, Cill and Meeting Rails (Scale 1:2)



 Drainage System

 Variable Dimensions  
(Dim shown is usually min)

 Fixed Dimensions

Tolerances: All tolerances are to George Barnsdale Standard Tolerance definitions (see supporting document for more detail) unless stated on the drawing.  
© George Barnsdale & Sons Ltd. All rights reserved. No part of this drawing may be reproduced without the permission of George Barnsdale & Son Ltd.

System: T-S3-174		
Title: Traditional - Tilting Sash Window (59mm)		
Scale:	Rev No:	Date:
As Shown	A	29-Sep-16
Drawn By:	Sheet No:	Status:
LS	1	WIP

**GEORGE BARNSDALE**  
Est. 1884  
High Street, Donington, Spalding, Lincs. PE11 4TA  
01775 82300  
www.georgebarnsdale.co.uk

# SASH AND FRAME OPTIONS

Cill Extension Option - 45mm - (Scale 1:2)

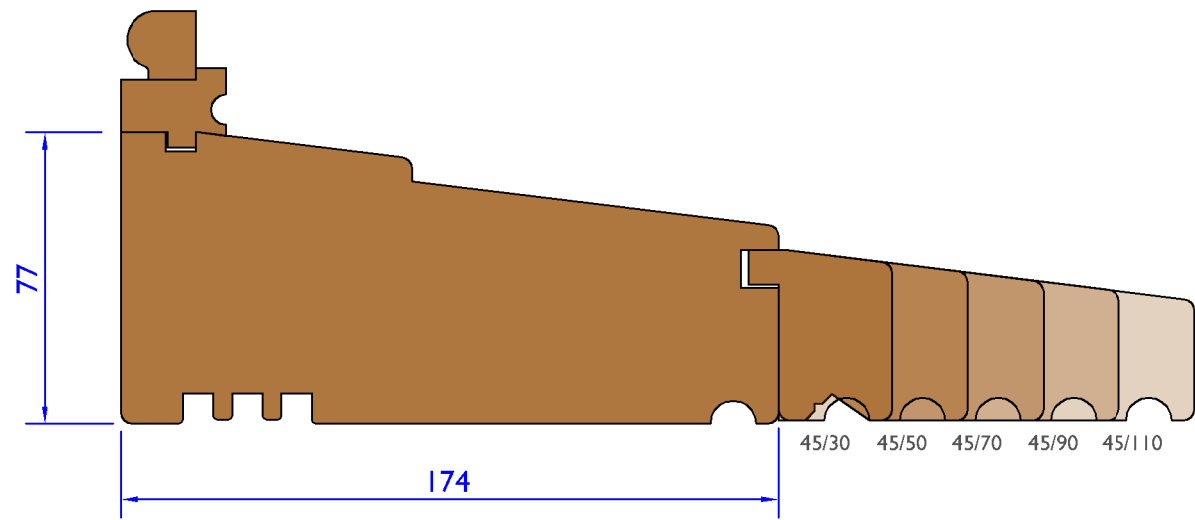

Cill Extension Option - 35mm - (Scale 1:2)

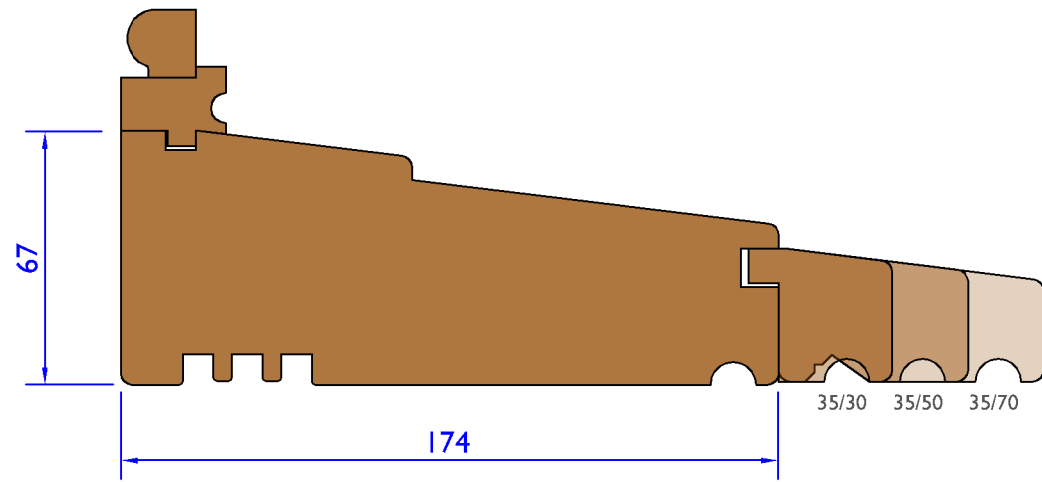

Cill Extension Option - 30mm - (Scale 1:2)

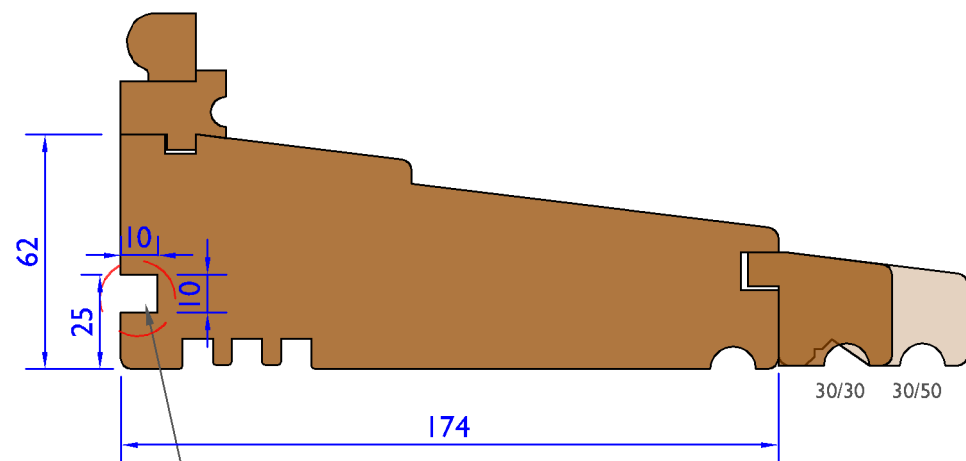

Optional windowboard groove

Transome Detail - Section D-D - (Scale 1:2)

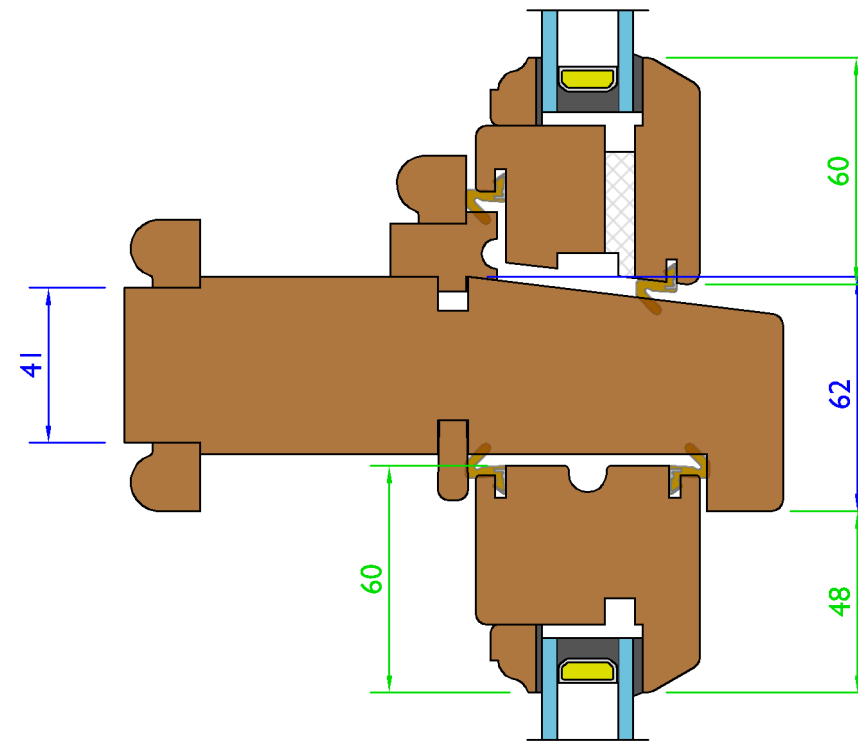

Solid Mullion Detail - Section E-E - (Scale 1:2)

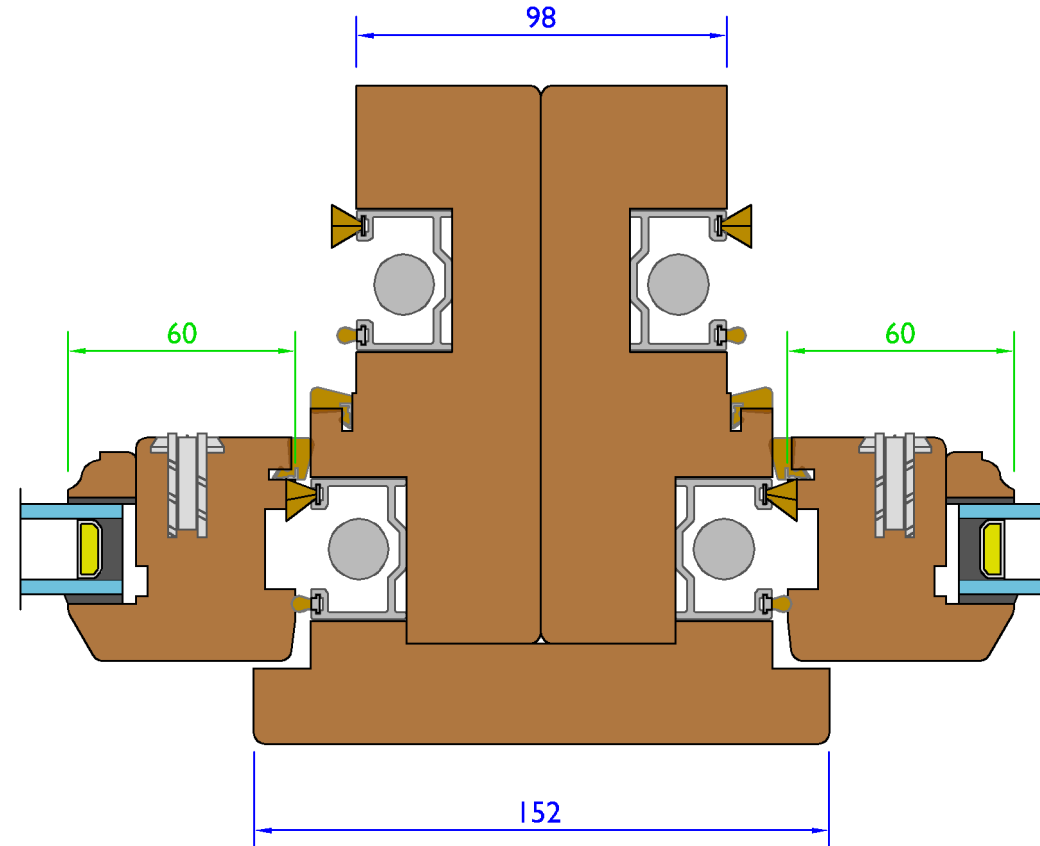

Arch Elevation - (Scale 1:20)

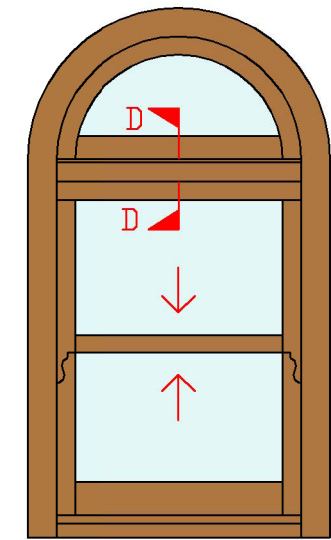

Double window Elevation - (Scale 1:20)

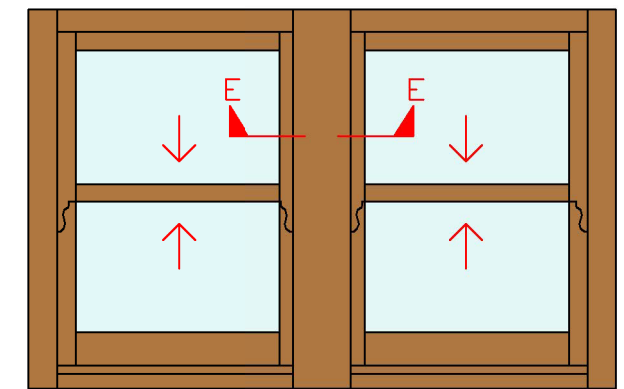

Drainage System

Variable Dimensions  
(Dim shown is usually min)

Fixed Dimensions

Tolerances: All tolerances are to George Barnsdale Standard Tolerance definitions (see supporting document for more detail) unless stated on the drawing.  
© George Barnsdale & Sons Ltd. All rights reserved. No part of this drawing may be reproduced without the permission of George Barnsdale & Son Ltd.

System: T-S3-174		
Title: Traditional - Tilting Sash Window (59mm)		
Scale:	As Shown	Rev No: A
Drawn By:	LS	Date: 29-Sep-16
		Sheet No: 2
		Status: WIP

**GEORGE BARNSDALE**  
Est. 1884  
High Street, Donington, Spalding, Lincs, PE11 4TA  
01775 82300  
www.georgebarnsdale.co.uk

Frame Vent Elevation Detail Showing Hidden Slot Size - (Scale 1:10)

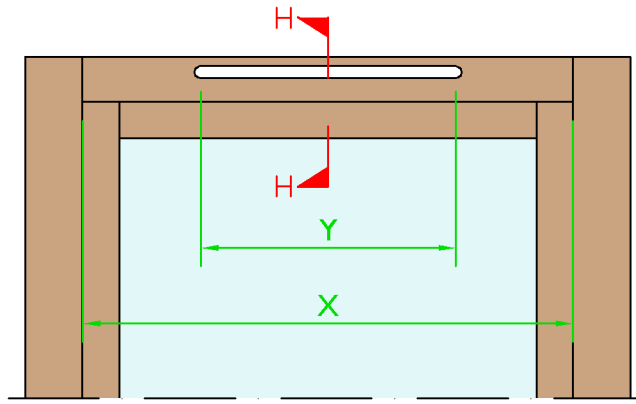

X	Y
≥420	336
330 - 419	244
275 - 329	195
<275	N/A

**ARCHED HEAD**

Arch Detail Section F-F - (Scale 1:2)

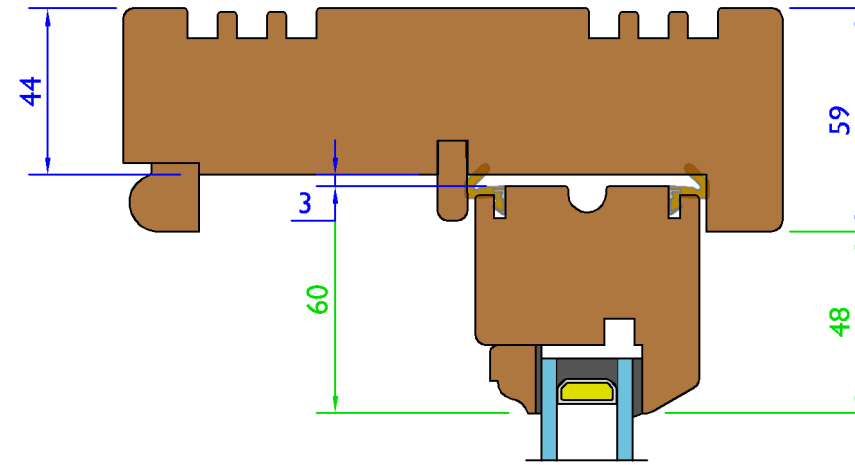

Arch Elevation - (Scale 1:10)

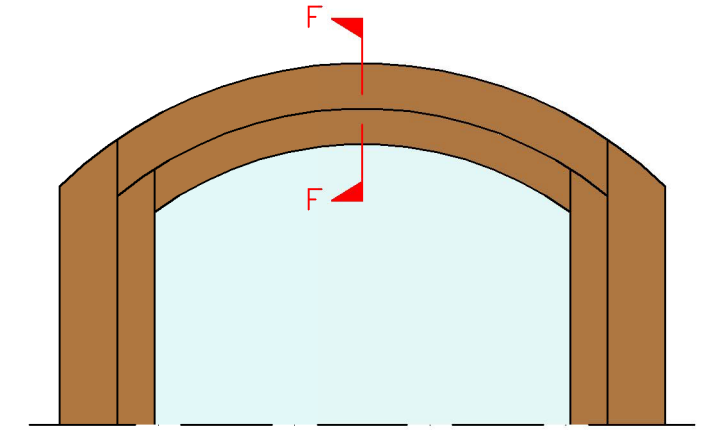

Head Vent Detail Section H-H - (Scale 1:2)

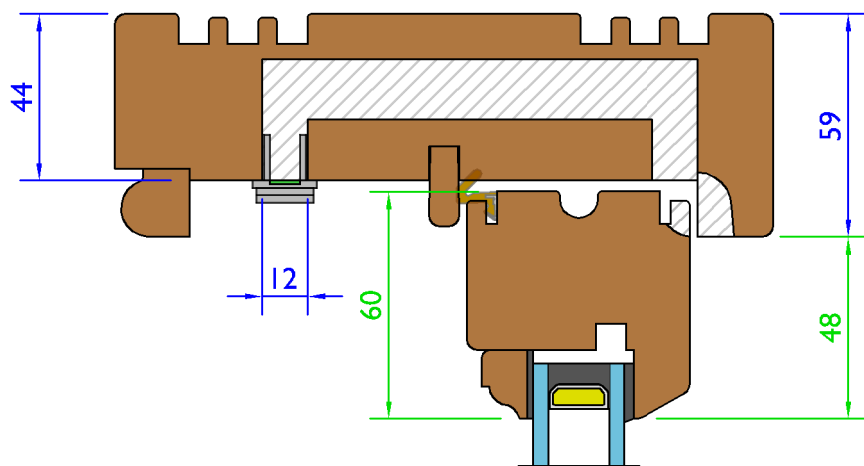

Large Arch Detail Section G-G - (Scale 1:2)

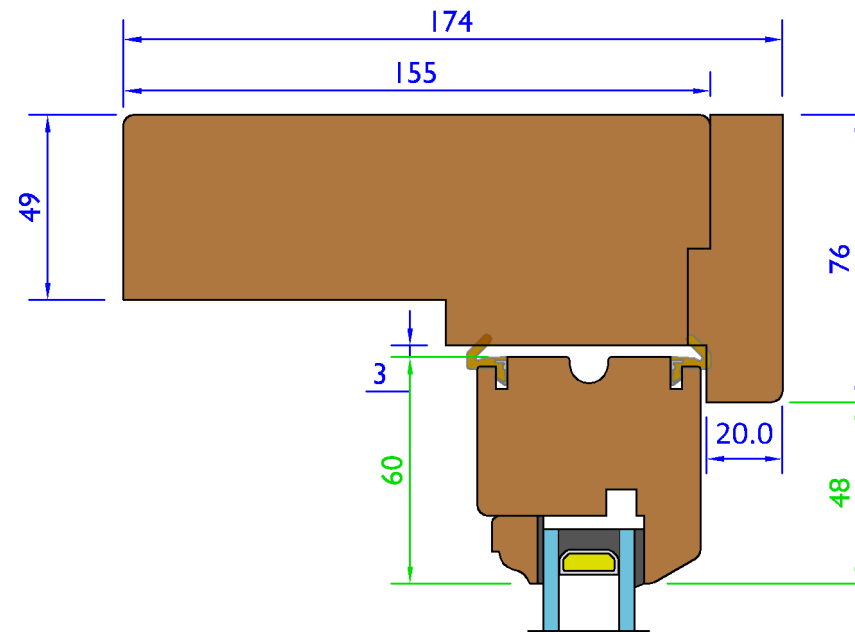

Semi-circular Arch Elevation - (Scale 1:10)

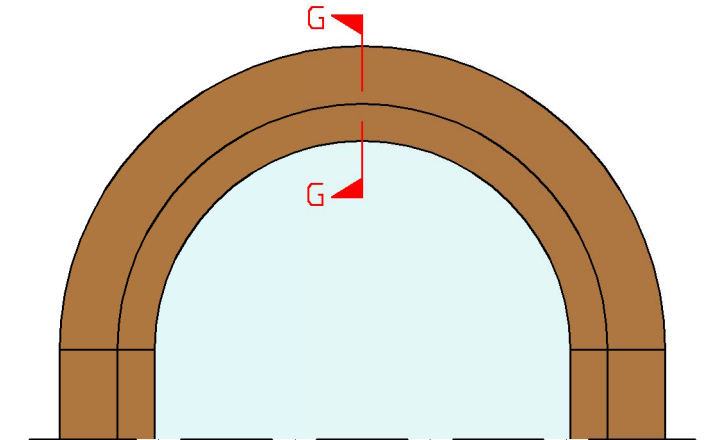

Extended Lining Option - (Scale 1:2)

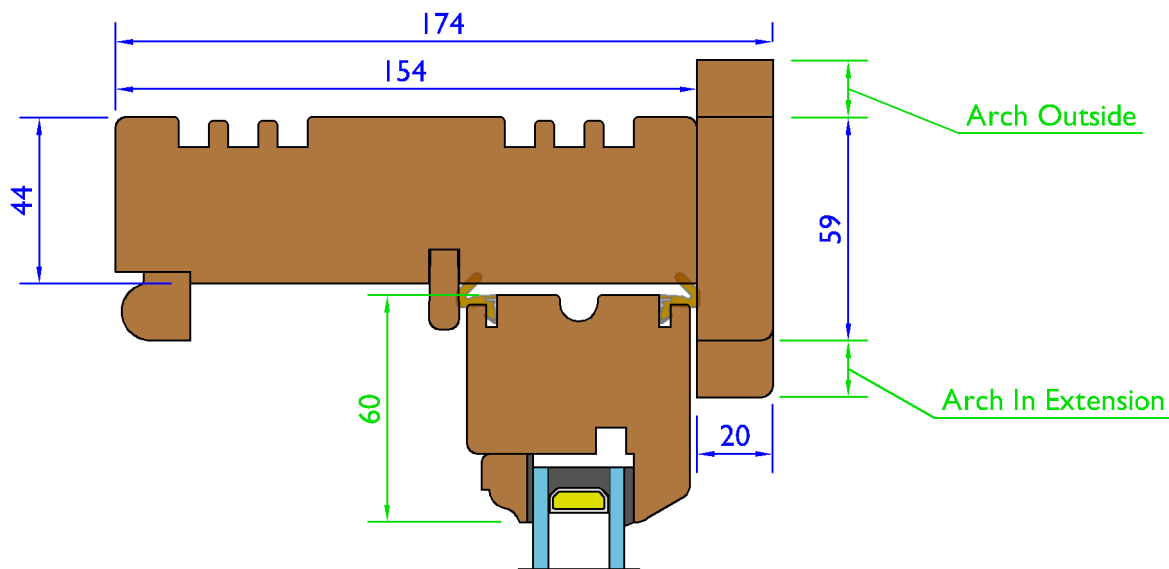

Vent System

Variable Dimensions  
(Dim shown is usually min)

Fixed Dimensions

Tolerances: All tolerances are to George Barnsdale Standard Tolerance definitions (see supporting document for more detail) unless stated on the drawing.  
© George Barnsdale & Sons Ltd. All rights reserved. No part of this drawing may be reproduced without the permission of George Barnsdale & Son Ltd.

System: T-S3-174		
Title: Traditional - Tilting Sash Window (59mm)		
Scale: As Shown	Rev No: A	Date: 29-Sep-16
Drawn By: LS	Sheet No: 3	Status: WIP

**GEORGE BARNSDALE**  
Est. 1884  
High Street, Donington, Spalding, Lincs. PE11 4TA  
01775 82300  
www.georgebarnsdale.co.uk

**SASH HORN OPTIONS** (Scale 1:2)

Sash Horn Type A

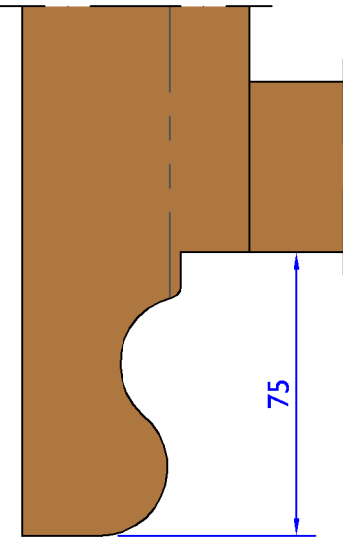

Sash Horn Type B

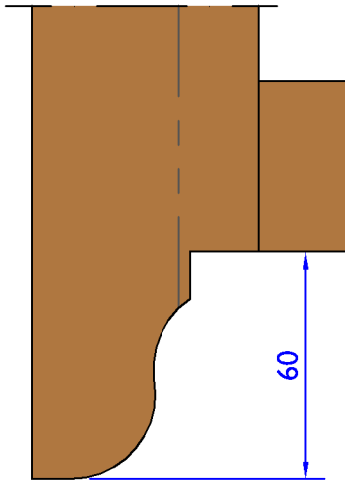

Sash Horn Type C

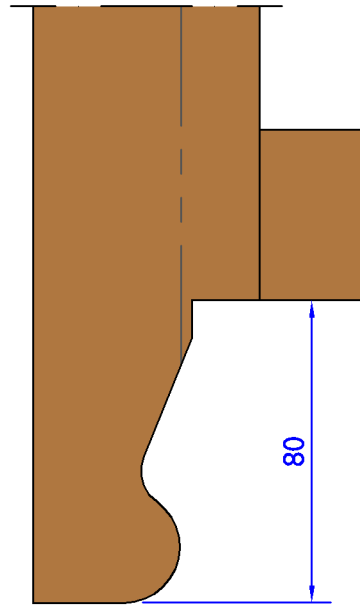

Sash Horn Type D

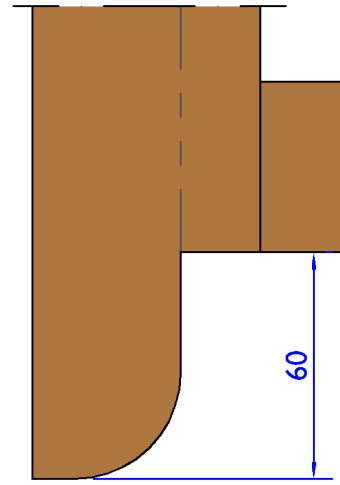

Sash Horn Type E

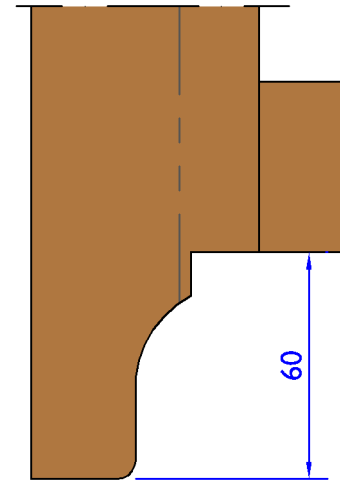

Sash Horn Type F

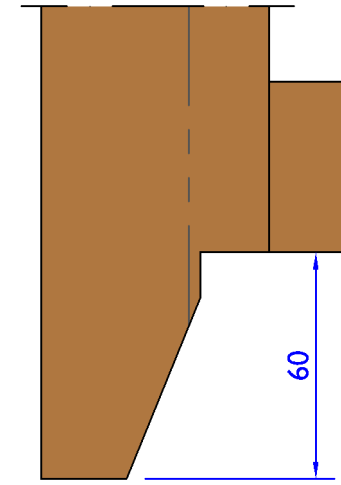

Sash Horn Type G

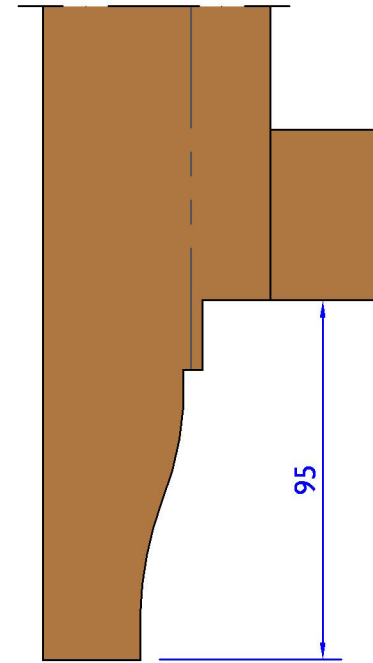

**Sash Pull Position** (sash width <900 mm) - (Scale 1:10)

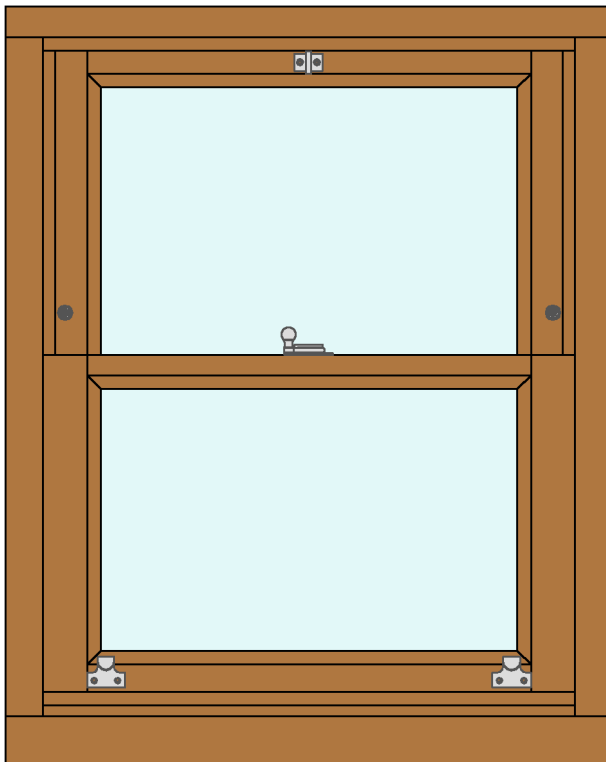

**Sash Pull + Fastener Position** (sash width >900 mm) - (Scale 1:10)

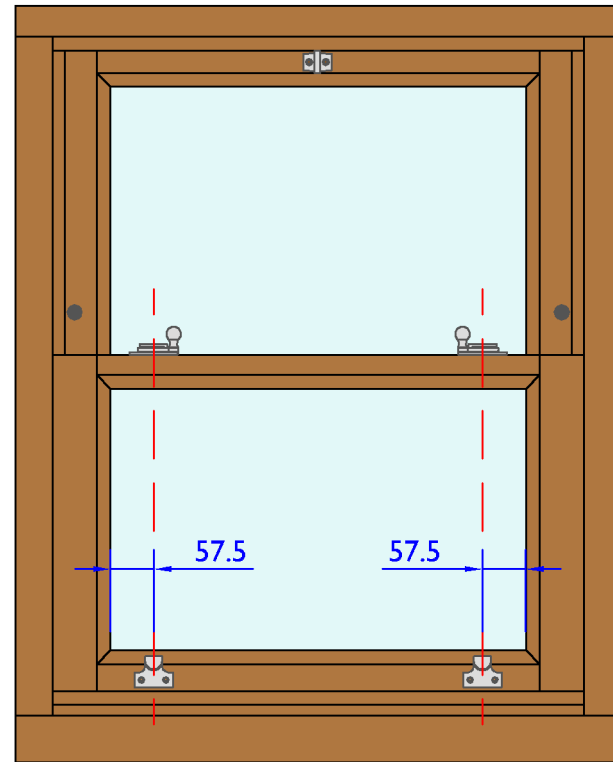

**Double Sash Stop Option** - (Scale 1:5)

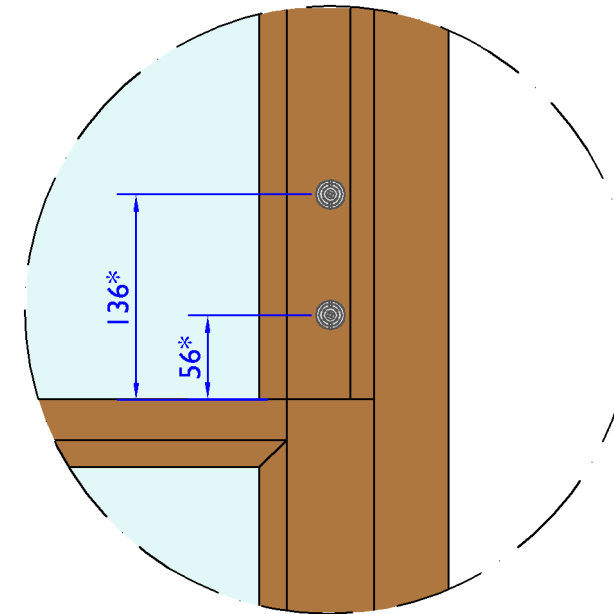

\* Dimensions shown provide (100mm and 20mm respectively), ventilation openings at the bottom of the window

Sash pull aligned with sash rebate. Sash fastener centralised unless glazing bar requires it to be offset (offset to RHS when viewed from inside unless specified otherwise)

Sash pull aligned with sash fastener. Pull and fastener position as shown unless glazing bar requires alternative position which should then be positioned for best aesthetic by operator.

— Variable Dimensions (Dim shown is usually min)  
— Fixed Dimensions

System: T-S3-174		
Title: Traditional - Tilting Sash Window (59mm)		
Scale: As Shown	Rev No: A	Date: 29-Sep-16
Drawn By: LS	Sheet No: 4	Status: WIP

Angular Bay Corner Post Option - (Scale 1:2)

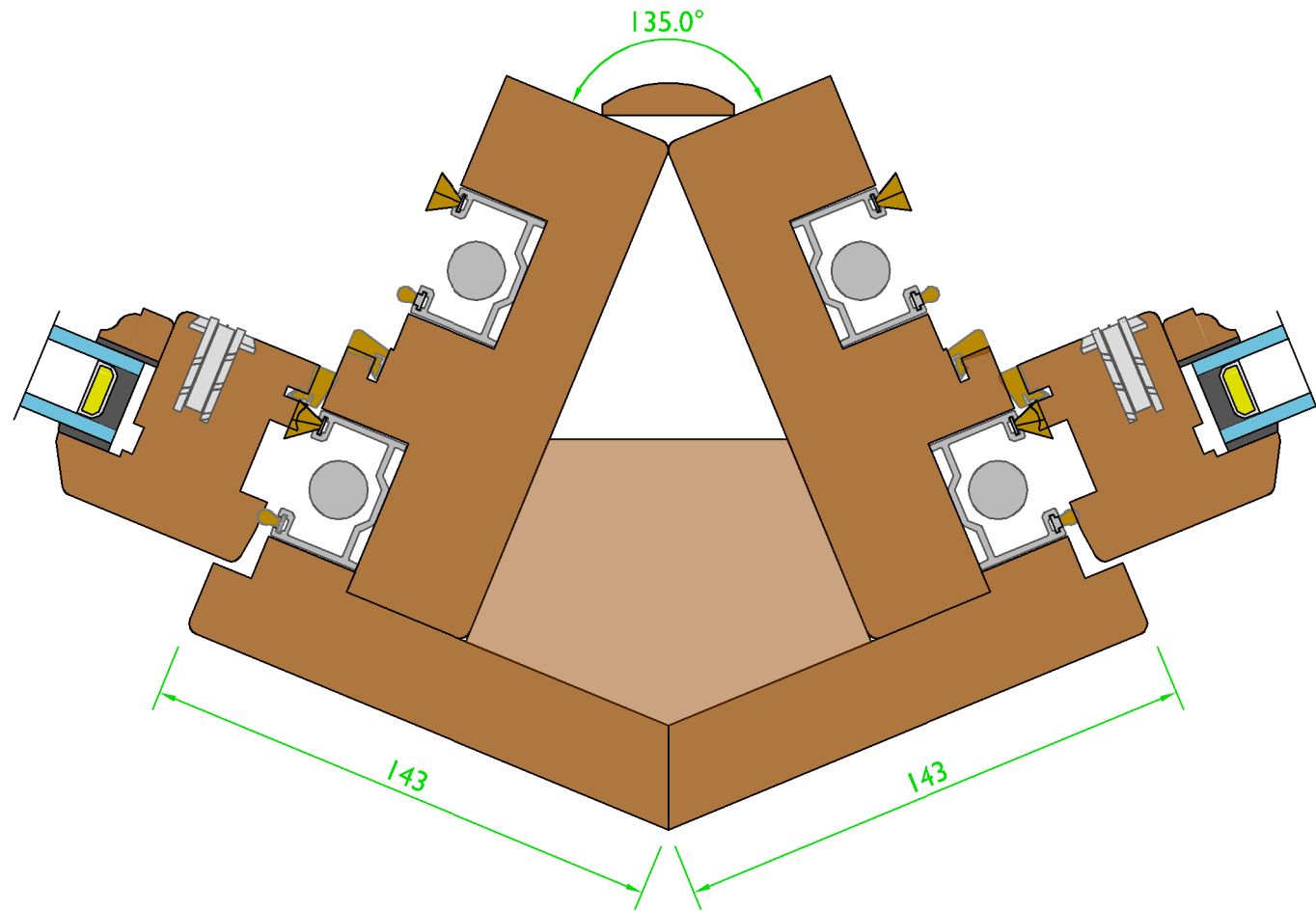

Angular Bay Corner Post Option - (Scale 1:2)

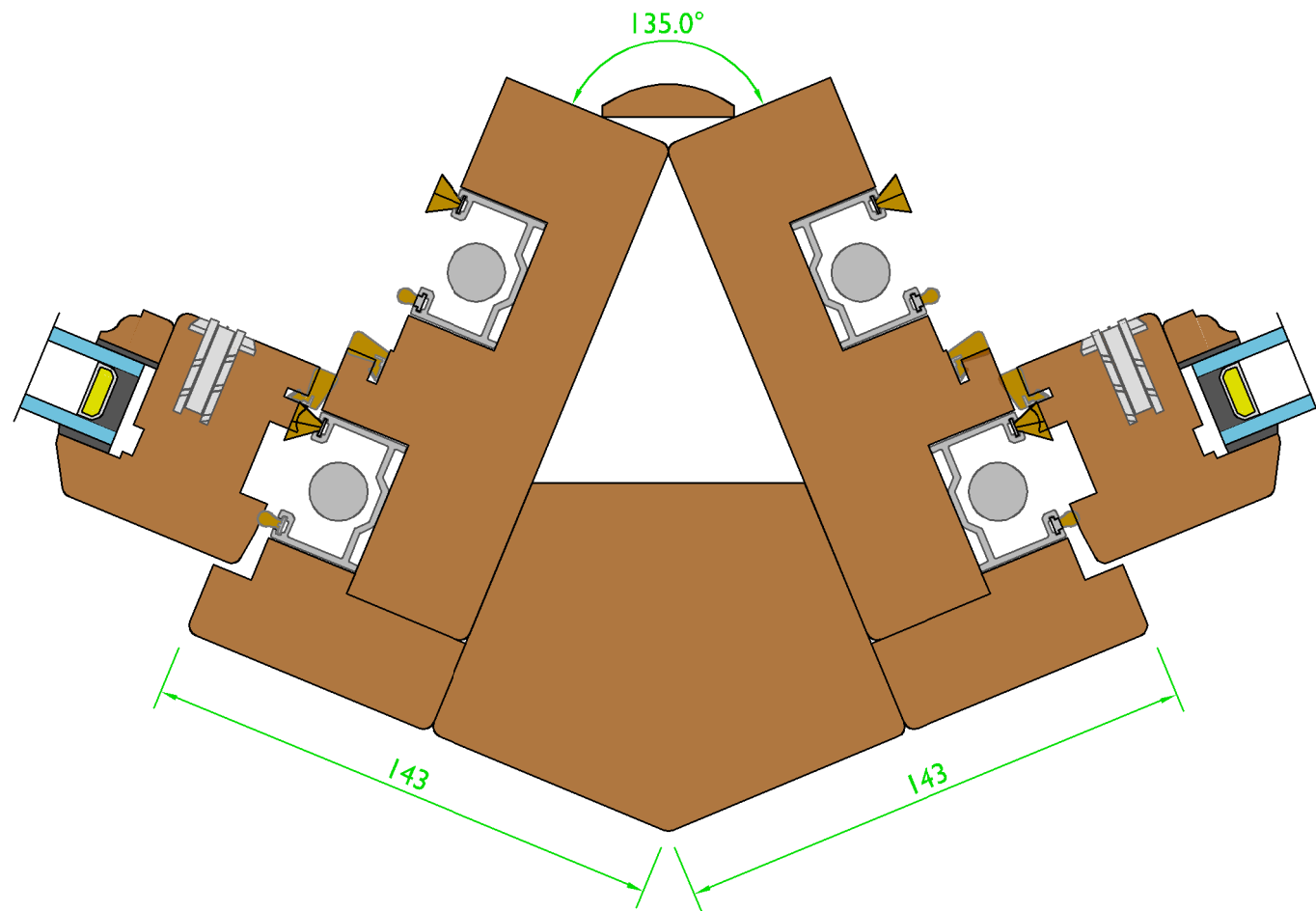

Square Bay Corner Post Option - (Scale 1:2)

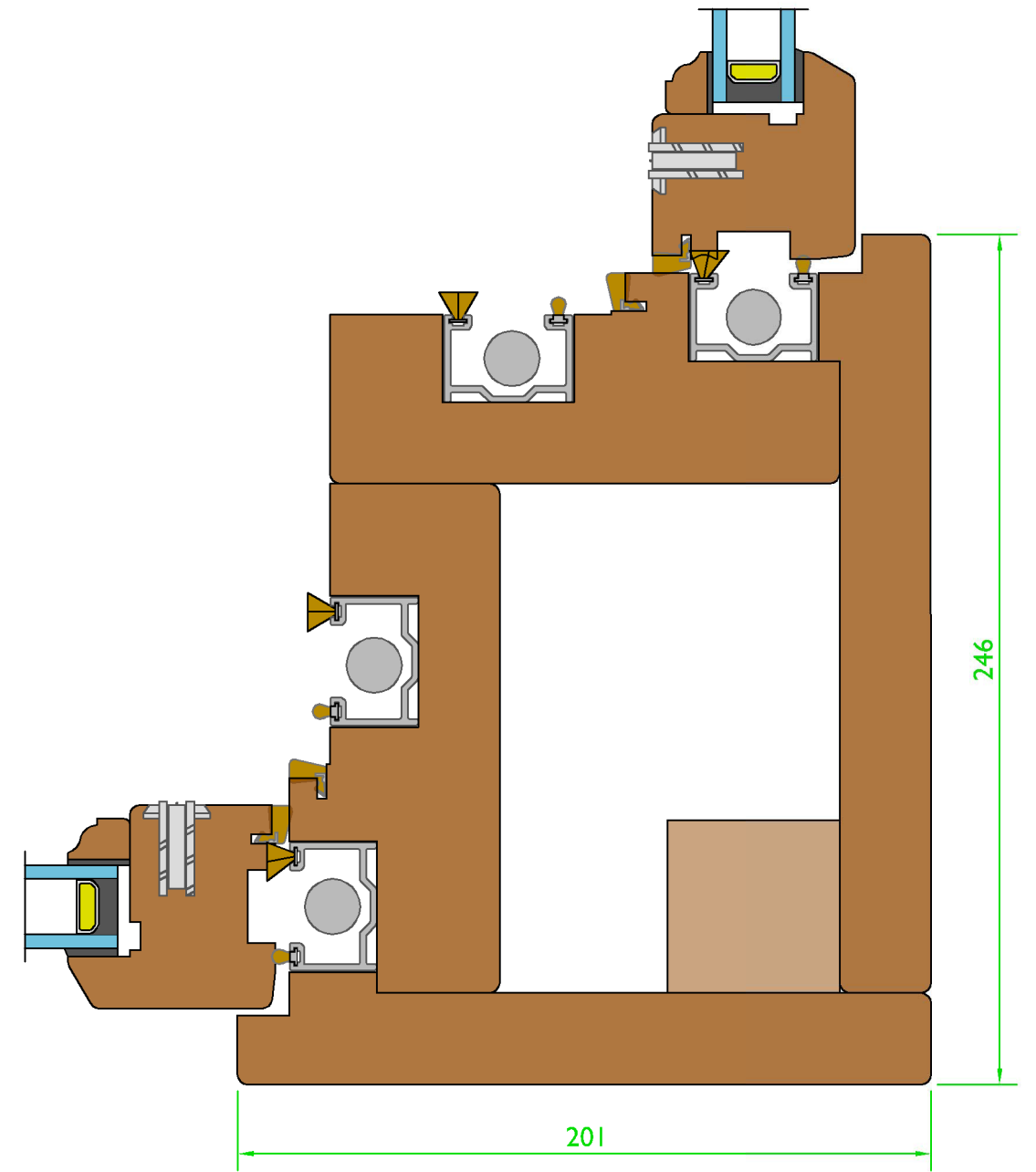

Variable Dimensions  
(Dim shown is usually min)

Fixed Dimensions

Tolerances: All tolerances are to George Barnsdale Standard Tolerance definitions (see supporting document for more detail) unless stated on the drawing.  
© George Barnsdale & Sons Ltd. All rights reserved. No part of this drawing may be reproduced without the permission of George Barnsdale & Son Ltd.

System: T-S3-174		
Title: Traditional - Tilting Sash Window (59mm)		
Scale:	As Shown	Rev No: A
Drawn By:	LS	Date: 29-Sep-16
		Sheet No: 5
		Status: WIP

**GEORGE BARNSDALE**  
Est. 1884  
High Street, Donington, Spalding, Lincs. PE11 4TA  
01775 82300  
www.georgebarnsdale.co.uk